

Polyanionic metal clusters: How to make 'em and to break 'em

Lutz Schweikhard* ¹

* University of Greifswald, Institute of Physics, Felix-Hausdorff-Str. 6, 17489 Greifswald, Germany

Synopsis Polyanionic metal clusters are produced by electron attachment in both Paul and Penning traps. After size and charge-state selection, the cluster properties are further investigated by various methods including photo-dissociation. Depending on the particular cluster species various decay modes are observed.

Clusters of a few up to a few hundred atoms bridge the gap between single atoms and the bulk phases of matter. Their properties are governed by their geometric and electronic structure. There is a competition between both aspects and depending on the material one or the other aspect dominates. Insight can be gained by varying both the cluster size, i.e. the number of constituents and thus their spatial arrangements, as well as their charge state – and thus the occupation of the electronic levels.

They depend on the cluster sizes under investigation [5]. Recently, new decay pathways were found, where larger fragments (either neutral or charged) break off (Fig. 2).

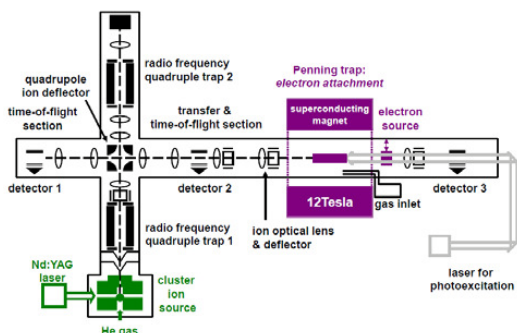

Figure 1. Schematic overview of ClusterTrap setup.

While there is a long tradition of the investigation of multiply charged cationic systems, the production of multiply negatively charged clusters, i.e. the attachment of further excess electron is more challenging. A successful general approach was found at CusterTrap [1] (Fig. 1) by subjecting mono-anionic clusters to an electron bath in a Penning trap [2,3]. Gold clusters, e.g., of charge states up to $z = -6$, i.e. with six excess electrons [1] and, recently, aluminum clusters even up to $z = -11$ have been observed. The corresponding appearance sizes, i.e. minimum clusters sizes, were studied in detail [4].

In addition, polyanionic clusters have been probed with respect to their stability and decay processes upon excitation, e.g. by laser irradiation. The decay pathways include electron emission and evaporation of neutral atoms.

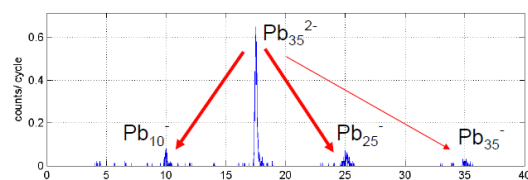

Figure 2. Cluster abundance spectrum after photo-excitation of size-selected dianionic lead clusters..

On the technical side, the production of polyanionic clusters by attachment of further excess electrons has been extended to Paul traps, i.e. rf traps that operate without a magnetic field (which, in the case of the high-mass clusters has to be provided by a superconducting magnet). To this end, a “3-state digital ion trap” has been developed [6] for the electron-beam irradiation of stored clusters in the field-free time windows of the guiding field [1].

Furthermore, the on-going investigations of polyanionic metal clusters include time-resolved measurements of delayed photodissociation, which have already proven very valuable in the case of mono-cations [7,8].

References

- [1] F. Martinez *et al.* 2014 *Int. J. Mass Spectrom.* **365-366** 266
- [2] A. Herlert *et al.* 1999 *Physica Scripta* **T80** 200
- [3] C. Yannouleas *et al.* 2001 *Phys. Rev. Lett.* **86** 2996
- [4] F. Martinez *et al.* 2015 *J. Phys. Chem. C* **119** 10949
- [5] A. Herlert *et al.* 2012 *New J. Phys.* **14** 055015
- [6] S. Bandelow *et al.* 2013 *Int. J. Mass Spectrom.* **353** 49
- [7] U. Hild *et al.* 1998 *Phys. Rev. A* **57** 2786
- [8] M. Vogel *et al.* 2001 *Phys. Rev. Lett.* **87** 013401

¹E-mail: lschweik@physik.uni-greifswald.de

